

1	2		3		4	
			REVISIONS			
REV	SYM	DRAFTER	CHECKER	DATE		
△		T.S.LII	W.H.HSU	03/15/03		
△		T.S.LII	W.H.HSU	02/17/04		
△		T.S.LII	W.H.HSU	06/14/04		

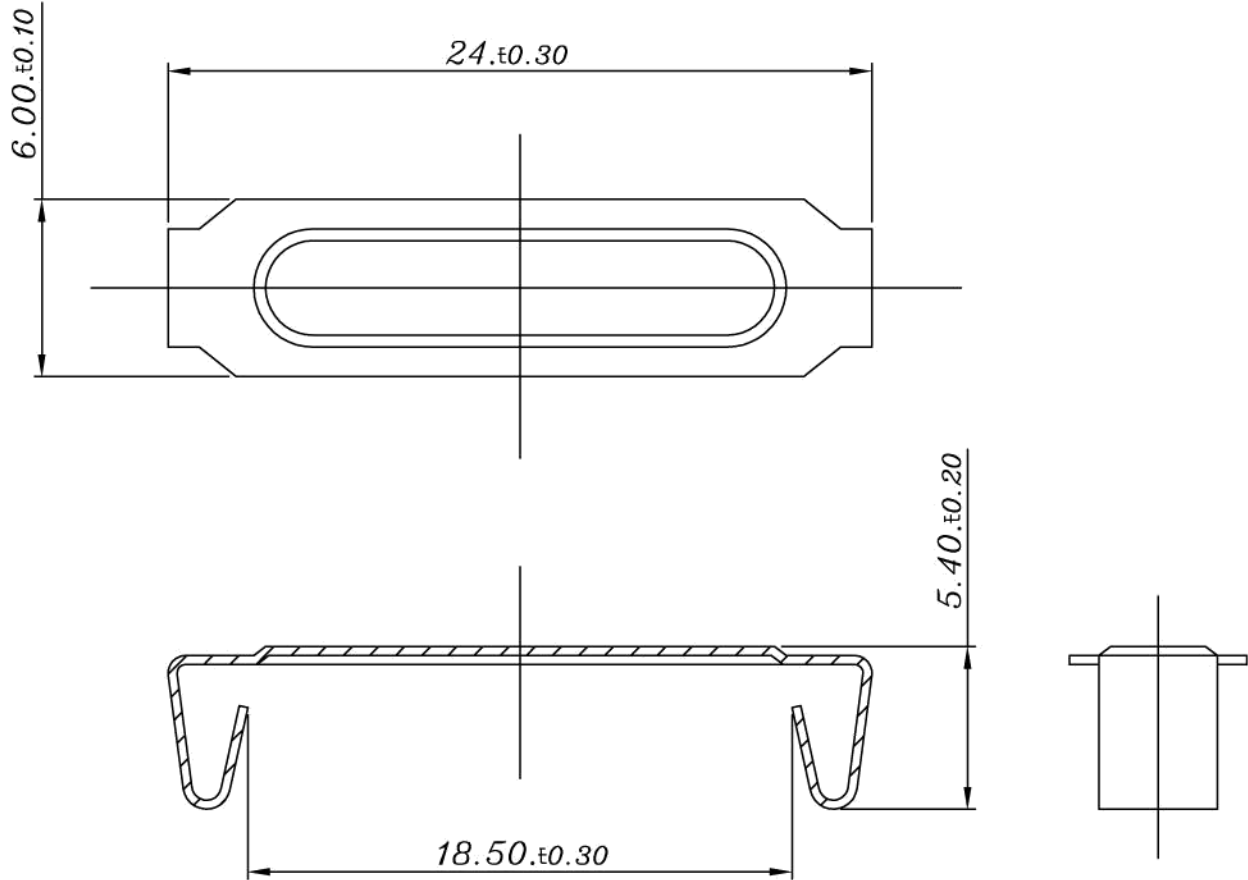

T=0.3

PART NO.	E-032C							
DWG NO.	Clamp EFD20 E-032C							
TBI NO.	MATERIAL (CLIP)							
407-01031.1	SUS 301			PART NO.	REV	MODE NO	PIN LOCATION	
				Finish: 1-1. Immersion gold on terminal. Thickness gold 0.075 μm (3 μ inches) min, Base nickel 0.625 μm (25 μ inches) min. 1-2. Immersion Sn on terminal. Terminal: Sn plating, 100, 5 μm (200 μ inches) min Base nickel 0.625 μm (25 μ inches) min. 1-3. Immersion Sn/Pb on terminal. Terminal: Sn/Pb plating, 90/10, 5 μm (200 μ inches) min Base nickel 0.625 μm (25 μ inches) min. (for pin GW type) 2. Coplanarity deviation: 0.004 inches max.			TOLERANCE	.X ± 0.15 .XX ± 0.10 .XXX ± 0.05
							UNIT	m/m
							SCALE	2 : 1
							REV	3